



Electric hob

## Vitroline Hi-light

Electric hob 52 cm - Three zones - Vertical edge - for flush-mount (FT) or over-mount (Q4) installation

Code: 7316 100

## Product Details

Materials/finishes	White Ceramic Glass
Edge/installation type	Vertical edge - for flush-mount (FT) or over-mount (Q4) installation
Cooking elements	Three zones
Command type	Touch Control
Power settings	9 power setting per zone
Dimension	Ø 520 mm
Cut out	Vedi scheda tecnica
Total power	4.100 W
Left	Ø 140 mm- 1.200 W
Centre	Ø 180 mm- 700/1.700 W
Right	Ø 140 mm- 1.200 W
Power Supply	220-230 V; 50-60 Hz

### Features

Zone multiple



End-of-cooking programming



Safety

Dimensions

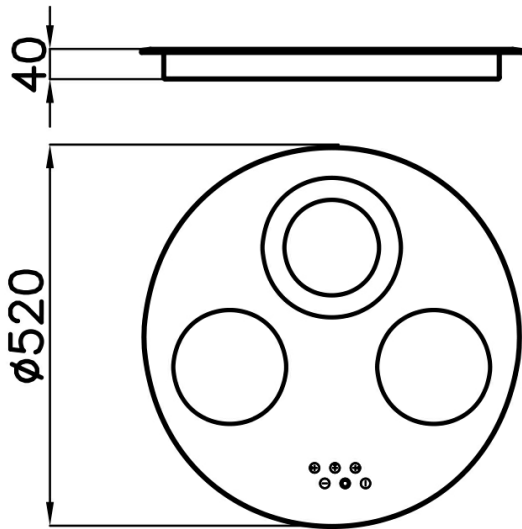

Cut out drawing

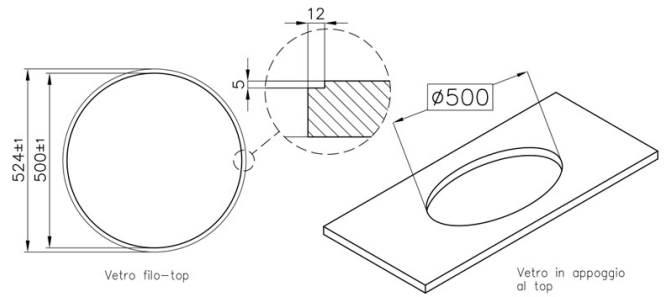

05-03-2019 18:37:37